

Features

- 1 GB DDRL3L System Memory
- 32MB NOR Flash, 256MB NAND Flash
- Supports Dynamic Frequency Selection (DFS)
- 2x2 On-board 2.4GHz radio, upto 573Mbps physical
- Data Rate
- 2x2 On-board 5GHz radio, upto 1201Mbps physical
- Data Rate

Applications

- 802.11ax MU-MIMO OFDMA Access Point
- Smart AP TWT

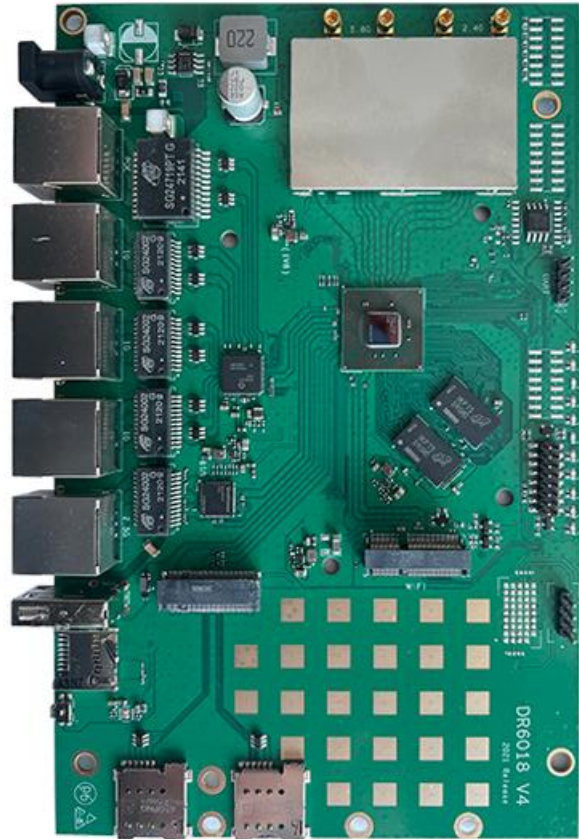

Product Description

DR6018 V4 based on IPQ6010 chipset is an enterprise wireless module integrated with 2 x2 5G high power Radio module and 2x2 2.4G high power Radio module designed specifically to provide users with mobile access to high-bandwidth video streaming, voice, and data transmission for office and challenging RF environment in factories, warehouses establishment.

Absolute Maximum Rating

Parameter	Rating	Unit
Supply Voltage	24V~48	V
Operating Temperature Range	-40 to +70	°C
Storage Temperature Range	-45 to + 105	°C
Operating Humidity Range	5 to +95 (non-condensing)	%
Storage Humidity Range	0 to +90 (non-condensing)	%



Hardware Specifications

Symbol	Parameter
CPU	Qualcomm-Atheros IPQ6010
CPU Frequency	Quad-core ARM 64 bit A53 @ 1.8 GHz processor
System Memory	1GB (2x 512MB)DDR3L 16-bit interface with 32-bit memory bus design
Ethernet Port	1 x 1Gbps Ethernet Ports & POE 3 x 1Gbps Ethernet Ports , 1x 2.5Gbps Ethernet Port,
NGFF Slot	M. 2 (NGFF) “E Key” Socket with MiniPCIe 3.0 (For WiFi Module) M. 2 (NGFF) “B Key” Socket with USB 3.0(For 5G Module)
SD Card Slot	1x SD Card Slot
USB /header	1x USB 2.0 Port
POE	24V~48V passive POE/Active POE(Suport 802.3bt)
DC Jack	24V power supply
LED header	LEDs
Serial Port	1x Serial Port 4 Pin Connector
Wireless	On- board 2x 2.4GHz MU- MIMO OFDMA 802.11b/g/n/ax, max 23dBm per chain On- board 2x 2.5GHz MU- MIMO OFDMA 802.11a/n/ac/ax, max 20dBm per chain 4 x MMCX Connectors
Bluetooth	optional
Nor Flash	8-32MB (normally is 8MB)
Nand Flash	256MB
DDR	1GB
Dimension	185mm x 116mm



Power Consumption

	Working Mode	Maxim Power Consumption
1	DR6018 startup	8W
2	DR6018 run with dual band WIFI on board	14 W
3	DR6018 run with DR9074	24W
4	DR6018 run with QUECTEL RM500Q-GL	24.5W
5	DR6018 run with DR9074 and QUECTEL RM500Q-GL	34 .5W



Radio TX Specifications(5180MHz-5825MHz)

Operating Mode	Data Rate	Power		Tolerance
		1 Chain	2 Chains	
5Ghz 802.11ax HE20	MCS0	27dBm	30dbm	±2dB
	MCS1	26dBm	29dBm	±2dB
	MCS2	26dBm	29dBm	±2dB
	MCS3	26dBm	29dBm	±2dB
	MCS4	25dBm	28dBm	±2dB
	MCS5	24dBm	27dBm	±2dB
	MCS6	23dBm	26dBm	±2dB
	MCS7	21dBm	24dBm	±2dB
	MCS8	20dBm	23dBm	±2dB
	MCS9	20dBm	23dBm	±2dB
	MCS10	20dBm	23dBm	±2dB
	MCS11	19dBm	22dbm	±2dB
5Ghz 802.11ax HE40	MCS0	27dBm	30dbm	±2dB
	MCS1	26dBm	29dBm	±2dB
	MCS2	26dBm	29dBm	±2dB
	MCS3	26dBm	29dBm	±2dB
	MCS4	25dBm	28dBm	±2dB
	MCS5	24dBm	27dBm	±2dB
	MCS6	23dBm	26dBm	±2dB
	MCS7	21dBm	24dBm	±2dB
	MCS8	20dBm	23dBm	±2dB
	MCS9	20dBm	23dBm	±2dB
	MCS10	20dBm	23dBm	±2dB
	MCS11	19dBm	22dbm	±2dB
	MCS0	27dBm	30dbm	±2dB



5Ghz 802.11ax HE80	MCS1	26dBm	29dBm	± 2dB
	MCS2	26dBm	29dBm	± 2dB
	MCS3	26dBm	29dBm	± 2dB
	MCS4	25dBm	28dBm	± 2dB
	MCS5	24dBm	27dBm	± 2dB
	MCS6	23dBm	26dBm	± 2dB
	MCS7	21dBm	24dBm	± 2dB
	MCS8	20dBm	23dBm	± 2dB
	MCS9	20dBm	23dBm	± 2dB
	MCS10	20dBm	23dBm	± 2dB
	MCS11	19dBm	22dbm	± 2dB

Radio TX Specifications(2412MHz-2482MHz)

Operating Mode	Data Rate	Power		Tolerance
		1 Chain	2 Chains	
2.4Ghz 802.11ax HE20	MCS0	27dbm	30dbm	±2dB
	MCS1	26dBm	29dBm	±2dB
	MCS2	26dBm	29dBm	±2dB
	MCS3	26dBm	29dBm	±2dB
	MCS4	25dBm	28dBm	±2dB
	MCS5	24dBm	27dBm	±2dB
	MCS6	23dBm	26dBm	±2dB
	MCS7	21dBm	24dBm	±2dB
	MCS8	20dBm	23dBm	±2dB
	MCS9	20dBm	23dBm	±2dB
	MCS10	20dBm	23dBm	±2dB
	MCS11	19dbm	22dbm	±2dB
2.4Ghz 802.11ax HE40	MCS0	27dbm	30dbm	±2dB
	MCS1	26dBm	29dBm	±2dB
	MCS2	26dBm	29dBm	±2dB
	MCS3	26dBm	29dBm	±2dB
	MCS4	26dBm	28dBm	±2dB
	MCS5	25dBm	27dBm	±2dB
	MCS6	24dBm	26dBm	±2dB
	MCS7	23dBm	24dBm	±2dB
	MCS8	20dBm	23dBm	±2dB
	MCS9	20dBm	23dBm	±2dB
	MCS10	20dBm	23dBm	±2dB
	MCS11	19dbm	22dbm	±2dB



Radio RX Specifications (5180MHz-5825MHz)

Operating Mode	Data Rate	RX Sensitivity	Tolerance
5GHz 802.11a	6Mbps	-96	±2dB
	54Mbps	-81	±2dB
5Ghz 802.11n/ac VHT20	MCS0	-96	±2dB
	MCS7	-78	±2dB
	MCS8	-76	±2dB
5Ghz 802.11n/ac VHT40	MCS0	-93	±2dB
	MCS7	-77	±2dB
	MCS8	-76	±2dB
	MCS9	-73	±2dB
5Ghz 802.11n/ac VHT80	MCS0	-90	±2dB
	MCS7	-74	±2dB
	MCS8	-71	±2dB
	MCS9	-68	±2dB
5Ghz 802.11ax HE20	MCS0	-95	±2dB
	MCS9	-76	±2dB
	MCS10	-73	±2dB
	MCS11	-70	±2dB
5Ghz 802.11ax HE40	MCS0	-93	±2dB
	MCS9	-73	±2dB
	MCS10	-70	±2dB
	MCS11	-67	±2dB
5Ghz 802.11ax HE80	MCS0	-90	±2dB
	MCS9	-70	±2dB
	MCS10	-67	±2dB
	MCS11	-65	±2dB



Radio RX Specifications (2412MHz-2482MHz)

Operating Mode	Data Rate	RX Sensitivity	Tolerance
2.4Ghz 802.11b	1Mbps	-98	±2dB
	2Mbps	-95	±2dB
	5.5Mbps	-92	±2dB
	11Mbps	-92	±2dB
2.4Ghz 802.11g	6Mbps	-94	±2dB
	54Mbps	-80	±2dB
2.4Ghz 802.11n/ac VHT20	MCS0	-92	±2dB
	MCS7	-75	±2dB
2.4Ghz 802.11n/ac VHT40	MCS0	-90	±2dB
	MCS7	-70	±2dB
2.4Ghz 802.11ax HE20	MCS0	-92	±2dB
	MCS8	-74	±2dB
	MCS9	-72	±2dB
	MCS10	-69	±2dB
	MCS11	-66	±2dB
2.4Ghz 802.11ax HE40	MCS0	-89	±2dB
	MCS8	-72	±2dB
	MCS9	-69	±2dB
	MCS10	-66	±2dB
	MCS11	-63	±2dB



Interface MAP

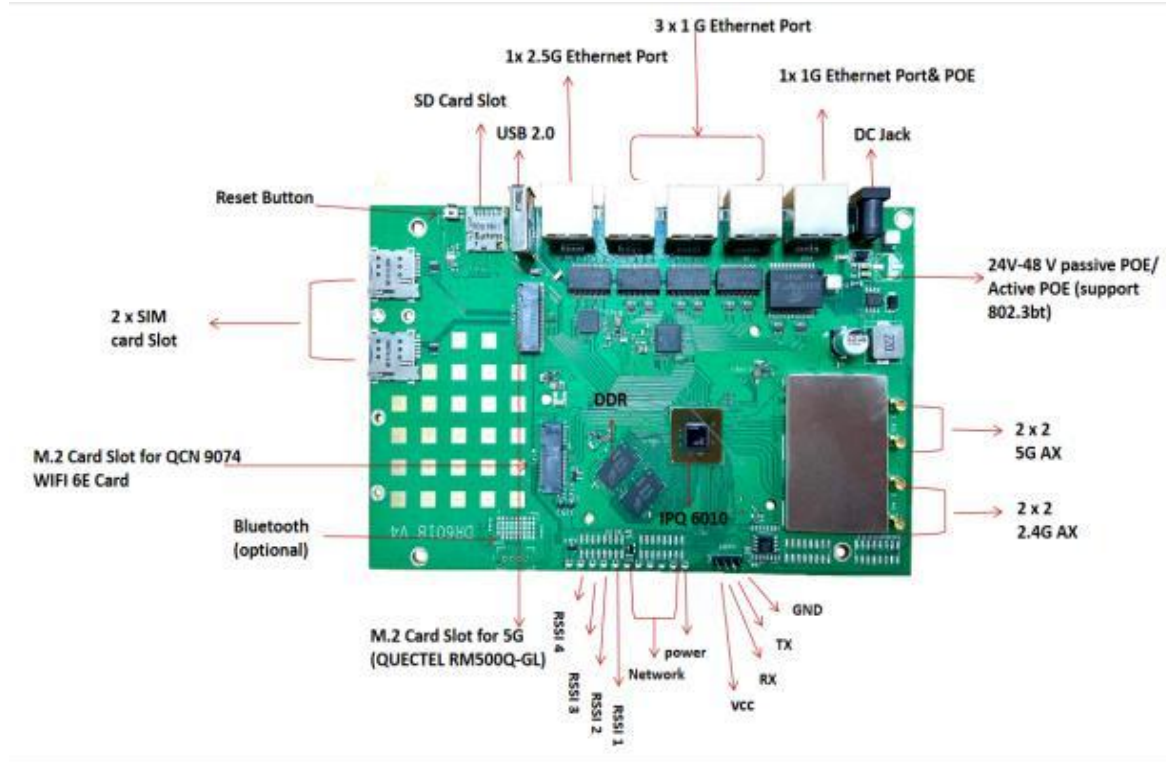

Block Diagram

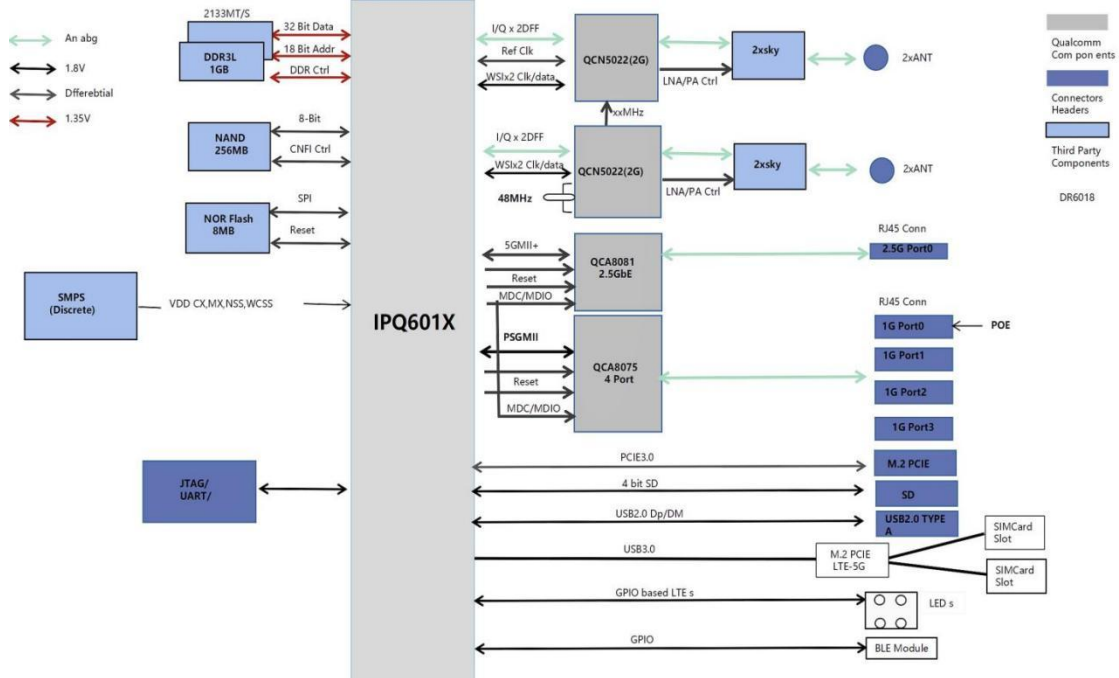



GPIO Pin Mapping

GPIO Pin Mapping			
Pin	Signal	Pin	Signal
GPIO 0	AUDIO MUTE BUT	GPIO 1	QPIC_BUSY_N
GPIO 2	MIC VOL M	GPIO 3	QPIC_WE_N
GPIO 4	QPIC _RE_N	GPIO 5	QPIC_DAT4
GPIO 6	QPIC_DAT5	GPIO 7	QPIC_DAT6
GPIO 8	QPIC_DAT7	GPIO 9	WPS
GPIO 10	QPIC_CLE_ N	GPIO 11	QPIC _NAND_CE_N
GPIO 12	QPIC_DAT1	GPIO 13	QPIC DAT2
GPIO 14	QPIC_DAT3	GPIO 15	QPIC_DAT0
GPIO 16	MIC KPD PWR N	GPIO 17	QPIC ALE
GPIO 18	KYPD HOME N	GPIO 19	GND
GPIO 20	Boot_ Config(PULL_ DOWN)	GPIO 21	MUTE ON
GPIO 22	ADC RST	GPIO 23	WSA SWR CLK
GPIO 24	WSA SWR DATA	GPIO 25	PWM LED RST
GPIO 26	Boot_ Config(PULL_ DOWN)	GPIO 27	WSA EN R
GPIO 28	WSA EN L	GPIO 29	PDM CLK0
GPIO 30	PDM DATA0	GPIO 31	PDM CLK1
GPIO 32	PDM DATA1	GPIO 33	EXT MCLK2 ADC
GPIO 34	MIC VOL P	GPIO 35	LED 5G
GPIO 36	PCIE0 WAKE	GPIO 37	LED 2GS
GPIO 38	SPI0 CLK	GPIO 39	SPI0 CS NI
GPIO 40	SPI0 MISO	GPIO 41	SPI0 MOSI
GPIO 42	BLSP2 SCL	GPIO 43	BLSP2 SDA
GPIO 44	BLSP2 UART RX	GPIO 45	BLSP2 UART TX
GPIO 46	BLSP5 SCL	GPIO 47	BLSP5 SDA



GPIO 48	NC	GPIO 49	Boot_Config(PULL_DOWN)
GPIO 50	LED_USB0	GPIO 51	BT_PRIORITY_PTA11
GPIO 52	WLA_ACTI_PTA12	GPIO 53	BT_ACT_PTA10
GPIO 54	Boot_Config(PULL_DOWN)	GPIO 55	NC
GPIO 56	NC	GPIO 57	NC
GPIO 58	NC	GPIO 59	PCIE0_CLK_REQ
GPIO 60	PCIE0_RSTn	GPIO 61	NC
GPIO 62	SD_DET	GPIO 63	SD_WP
GPIO 64	MDC	GPIO 65	MDIO
GPIO 66	SD_LDO_EN	GPIO 67	NC
GPIO 68	NC	GPIO 69	SPI_CLK_UART_RTSn
GPIO 70	SPI_CS_UART_CTSn	GPIO 71	SPI_MISO_UART_RX
GPIO 72	SPI_MOSI_UART_TX	GPIO 73	USB_OTG
GPIO 74	NC	GPIO 75	Malibu_RESET
GPIO 76	NAPA_INT0	GPIO 77	NAPA_RESET
GPIO 78	QTZ_INT	GPIO 79	QTZ_RESET



Boot Config Swit

Boot_ Config Switch1(S7)			
Boot_ Config			Boot up Interface Select
S7A	S7B	S7C	
0	0	0	SPI NOR. (Default)
0	0	1	eMMC
0	1	0	QPIC, Parallel NAND
0	1	1	USB2.0
1	0	0	SPI-NOR-GPT
S7D			Boot up Interface Select
0			Boot from code ram. (Default)
1			Boot from ROM
Boot_ Config Switch2(S9)			
Boot_ Config			Boot up Interface Select
0			No auth.(Default)
1			Auth is required